

DYNAMIC ENGINEERING

150 DuBois St. Suite C, Santa Cruz CA 95060

831-457-8891 Fax 831-457-4793

<http://www.dyneng.com>

sales@dyneng.com

Est. 1988

User Manual

DESWBO

“Dynamic Engineering SpaceWire Break Out”

SpaceWire Connection Status Monitor



Revision A4

Corresponding Hardware: Revision A-D

10-2006-1004

Corresponding Firmware: Revision B

DESWBO

SpaceWire Connection Status Monitor

Dynamic Engineering
150 DuBois St. Suite C
Santa Cruz, CA 95060
831-457-8891
831-457-4793 FAX

©2005-2018 by Dynamic Engineering.
Other trademarks and registered trademarks are owned by
their respective manufactures.
Manual Revision A4. Revised 11/19/18

This document contains information of proprietary interest to Dynamic Engineering. It has been supplied in confidence and the recipient, by accepting this material, agrees that the subject matter will not be copied or reproduced, in whole or in part, nor its contents revealed in any manner or to any person except to meet the purpose for which it was delivered.

Dynamic Engineering has made every effort to ensure that this manual is accurate and complete. Still, the company reserves the right to make improvements or changes in the product described in this document at any time and without notice. Furthermore, Dynamic Engineering assumes no liability arising out of the application or use of the device described herein.

The electronic equipment described herein generates, uses, and can radiate radio frequency energy. Operation of this equipment in a residential area is likely to cause radio interference, in which case the user, at his own expense, will be required to take whatever measures may be required to correct the interference.

Dynamic Engineering's products are not authorized for use as critical components in life support devices or systems without the express written approval of the president of Dynamic Engineering.

Connection of incompatible hardware is likely to cause serious damage.



Table of Contents

PRODUCT DESCRIPTION	4
THEORY OF OPERATION	9
SPECIFICATIONS	11
ORDER INFORMATION	11

List of Figures

FIGURE 1	DESWBO BLOCK DIAGRAM	4
FIGURE 2.	DATA FLOW	5
FIGURE 3.	NULL DETECTION SEQUENCE	6
FIGURE 4.	PARITY COVERAGE	7
FIGURE 5	SPACEWIRE DATA STROBE ENCODING	9
FIGURE 6	DESWBO CONNECTIONS	10

Product Description

The Dynamic Engineering SpaceWire Break-Out (DESWBO) board monitors the signals of a single SpaceWire link. The board has two 9-pin MDM connectors labeled Node_0 and Node_1. These connect to the two nodes of a SpaceWire network link. The link remains connected while the signals pass through DESWBO. The link is tested by monitoring the signals from each node.

The LVDS signals from each node are converted to single-ended signals by LVDS receivers and then routed to an FPGA as well as LVDS transmitters where they are converted back to LVDS signals and sent to the opposite node. The FPGA contains the equivalent of two SpaceWire receiver modules that decode the SpaceWire signals and extract the various data and control characters. See block diagram below.

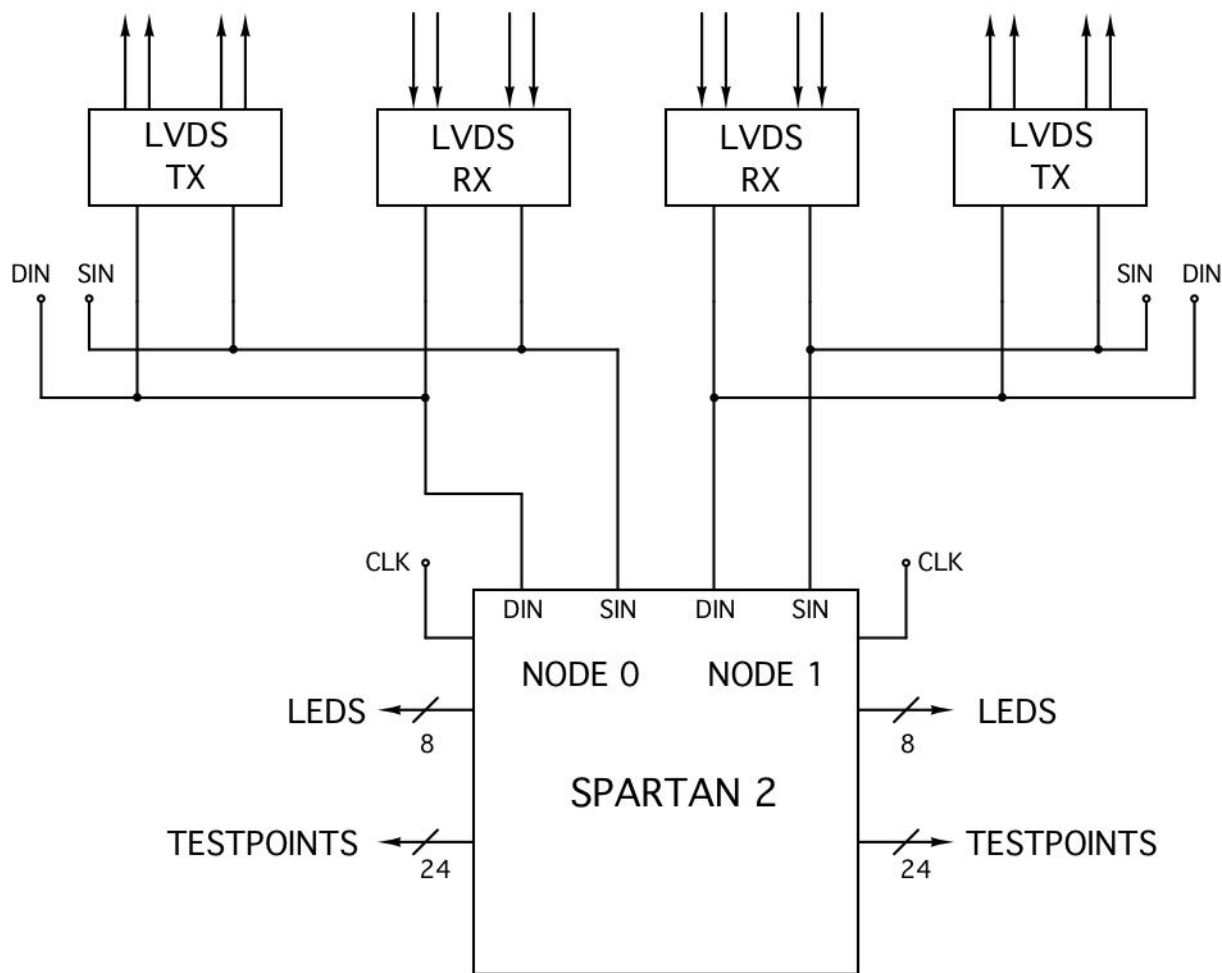

FIGURE 1

DESWBO BLOCK DIAGRAM

The end-of-packet, got-data and got-fct signals from each node are connected to pulse capture and extension circuits to drive three green LED's. The error-end-of-packet, parity error, escape error, credit error and disconnect error signals for each node drive five red LED's. These combined sixteen LED's provide a quick status of link activity and health.

There are 24 test points for each node driven by the real-time signals from the SpaceWire character receivers. Two test points for each node are connected to the DIN and SIN headers from the LVDS receivers. The recovered clock from the SpaceWire bit receivers for each node is available on a testpoint to provide a reference for the DIN and SIN signals.

Note: Data is valid on both the rising and falling edge of the recovered clock.

Test point signals: (labeled in silk-screen)

Parallel data bits(0-7)

Data characters contain a parity-bit, a data control flag and eight bits of data. The data control character is set to zero to indicate that the current character is a data character. The eight-bit data value is transmitted least-significant bit first. This is illustrated in figure 2 below.

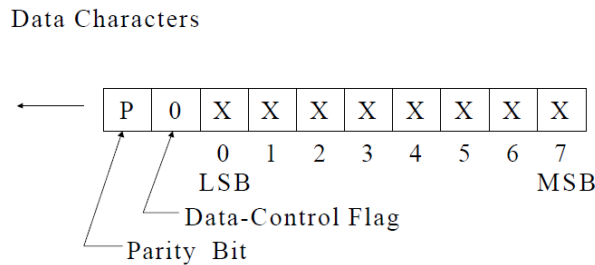

FIGURE 2.

DATA FLOW

Credit count bits(0-5)

The transmitter keeps a credit count of the number of Normal-characters that it has been authorized to send. Each time a link interface receives an FCT its transmitter increments the credit count by eight. Whenever the transmitter sends an N-Char it decrements the credit count by one. If the credit count reaches zero the transmitter will cease sending N-Chars until it receives another FCT increasing the credit count again to eight. When the credit count is zero the transmitter will continue to send link-characters (NULLs or FCTs). After a reset the initial value of credit count will be zero. If the credit count is at its maximum value when an FCT is received that FCT will be ignored. The maximum credit count is at least 56.

Parallel data strobe encoding scheme is a sequence of data bits encoded as the original data bit sequence, and the strobe which changes states whenever the data bit sequence does not.

Note: either edge of either signal [SIN, DIN] is used to capture the data bit immediately following the transition.

NULL received token sent to keep the data link active when there are no data or control characters to send. NULL detection is enabled whenever the receiver is enabled. Any sequence of bits encountered prior to the first NULL will be ignored. A NULL detection sequence example is shown below in figure 3.

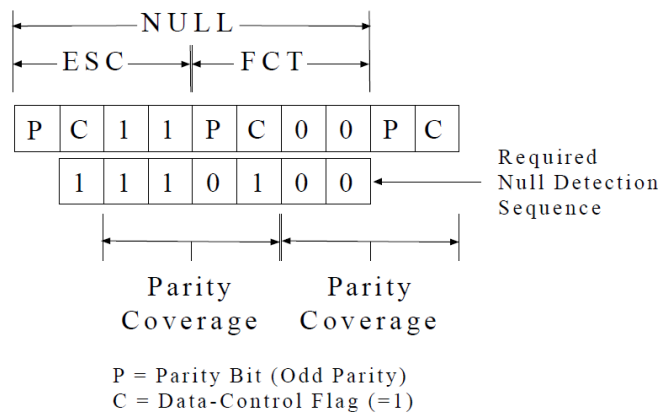

FIGURE 3. NULL DETECTION SEQUENCE

FCT received flow control token is a control character used to manage the flow of data across a link, indicating there is space for 8 more normal characters in the receiver buffer.

Timecode received code used to distribute system time over a SpaceWire network, which comprises ESC followed by a single data character holding six bits of the system time and two reserved bits.

End-of-Packet control character which indicates the end of a packet

Error End-of-Packet indicates the end-of-packet control character was not seen

Credit error credit error occurs if data is received when the host system is not expecting anymore data. i.e. when all the N-Chars expected, according to the requested “8 more” N-Chars and subsequent transmitted FCT’s, have been received. A credit error ought never to occur and indicates that some undetected error has occurred on the link affecting the transfer of FCT’s.

Disconnect error is an error condition asserted when the length of time since the last transition on the data or strobe lines was longer than 850 ns nominal.

Escape error occurs if an ESC character is followed by any character other than an FCT (ESC followed by a FCT is a NULL). Escape error detection is enabled whenever the receiver is enabled after the first NULL has been received.

Parity error a parity bit is assigned to each data or control character to support the detection of transmission errors. The parity bit covers the the previous eight bits of a data character or two bits of a control character, and the current data-control flag. See figure 4 below.

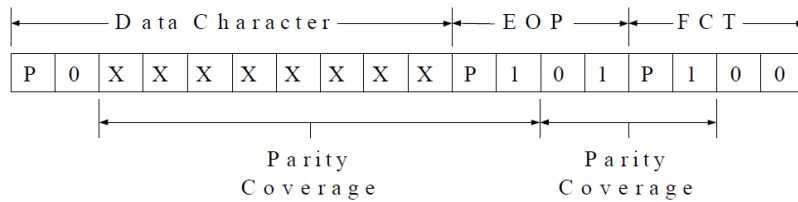

FIGURE 4.

PARITY COVERAGE

DESWBO is powered by an external 5-volt supply and on-board regulators for the various operating voltages required. There is no direct ground reference between the DESWBO and the inter-connected ports. This does not affect operation. When the signals on the test points are probed, the probe grounds need to be connected to a local DESWBO ground pin to allow accurate waveform detection.

In accordance with the SpaceWire standard; pin 3 on each of the MDM connectors is tied via 10 ohms to ground with a .1 uF cap in parallel. Standard SpaceWire cabling will have the RX side on the DESWBO [SIN, DIN] open on pin 3 for the signals received at the DESWBO and referenced to pin 3 for the signals transmitted by DESWBO [SOUT, DOUT].

Theory of Operation

SpaceWire is designed for transferring data from one point to another using the SpaceWire protocol as specified in document ECSS-E-50-12A, published by the European Cooperation For Space Standardization dated 24 January 2003. SpaceWire links are full-duplex, point-to-point, serial data communication links.

SpaceWire uses Data-Strobe encoding where clock and data information are sent on two paired serial links. Exactly one transition occurs in either the data line or the strobe line at the end of each bit period allowing the clock to be recovered from the data strobe pair. The timing is shown in figure 1.

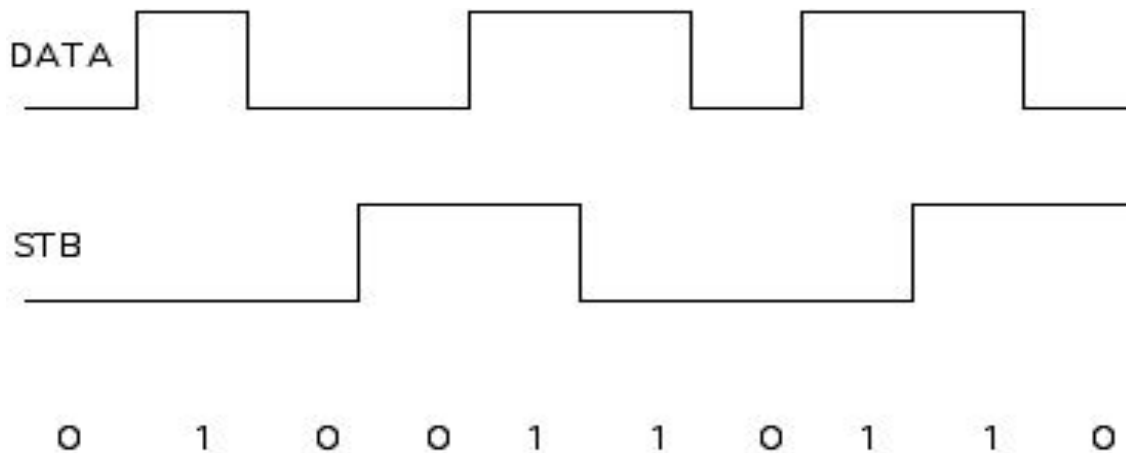

FIGURE 5 SPACEWIRE DATA STROBE ENCODING

Various bit sequences are defined by the specification to implement connection, flow control, system time distribution, and data transfer. DESWBO is designed to detect and decode these bit sequences, and issue signals indicating what types of characters are passing between nodes as well as the data contents of data and timecode characters.

A running count of flow control credits for each node is calculated by DESWBO. The FCT's from the receiving node, and the N-characters from the transmitting node are used to calculate the current available byte count. The count can be monitored on the test points. The process is repeated to provide a count for both directions.

As a side note: if the count goes above 56 or negative an error has occurred and the link should reset and retrain. *This activity is controlled by the connected nodes not DESWBO.*

Refer to the SpaceWire specification for the details of the link interface.

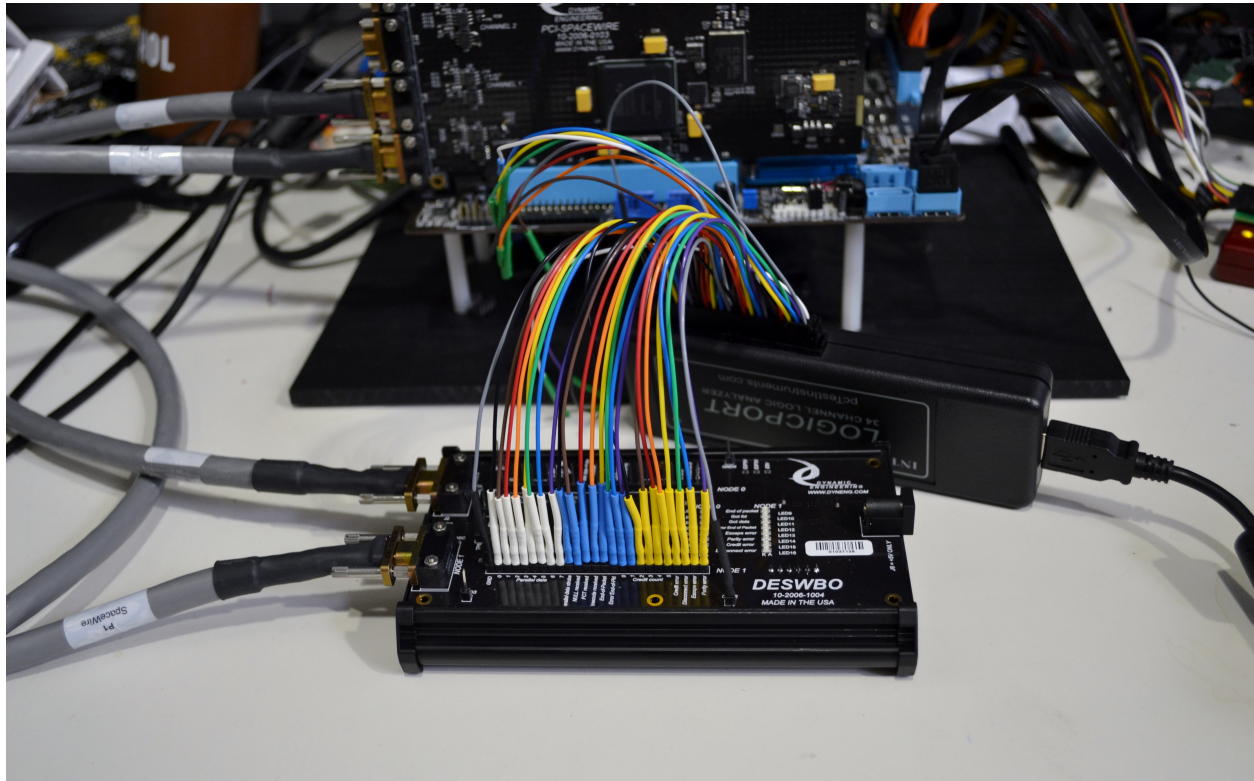

FIGURE 6

DESWBO CONNECTIONS

DESWBO is shown connected to two ports on PCI-SpaceWire. We have used the “LogicPort” inexpensive USB Logic Analyzer to connect to the test points on DESWBO. With the LA it is easy to see the credit count, decoded data, various errors [Parity, Escape, Disconnect, Credit], predecoded events [Null, FCT, TimeCode, End of Packet, Error End of Packet, Data Byte].

Specifications

Serial Interfaces:	Two standard SpaceWire node connections
Interface Options:	Two 9-pin MDM connectors for Node_0 and Node_1 ⇔ standard MDM connectors to use with Standard SpaceWire cables.
Dimensions:	2.788" x 5.475"
Construction:	Hi Temp, FR4 Multi-Layer Printed Circuit, Through-Hole and Surface-Mount Components
Temperature Coefficient:	2.17 W/°C for uniform heat across board
Power:	External wall mount 5V transformer provided.

Order Information

DESWBO	SpaceWire breakout suitable for monitoring 1 SpaceWire link and reporting status and errors in real time. For additional details please visit our webpage. http://www.dyneng.com/deswbo.html
MDMCable9	9-pin MDM connectors suitable for SpaceWire node interconnection. Multiple lengths available.

All information provided is Copyright Dynamic Engineering