

DYNAMIC ENGINEERING

435 Park Dr., Ben Lomond, Calif. 95005

831-336-8891 Fax 831-336-3840

<http://www.dyneng.com>

sales@dyneng.com

Est. 1988

User Manual

PMC-SpaceWire-BS2BI

Two Line Bi-directional Serial Interface PMC Module

Revision A

Corresponding Hardware: Revision B/C

10-2004-0802/0803

Corresponding Firmware: Revision B

PMC-SpaceWire-BS2BI
Two Line Bi-Directional Serial Interface
PMC Module

Dynamic Engineering
435 Park Drive
Ben Lomond, CA 95005
831-336-8891
831-336-3840 FAX

©2005-2006 by Dynamic Engineering.
Other trademarks and registered trademarks are owned by their
respective manufactures.
Manual Revision A. Revised October 3, 2006

This document contains information of proprietary interest to Dynamic Engineering. It has been supplied in confidence and the recipient, by accepting this material, agrees that the subject matter will not be copied or reproduced, in whole or in part, nor its contents revealed in any manner or to any person except to meet the purpose for which it was delivered.

Dynamic Engineering has made every effort to ensure that this manual is accurate and complete. Still, the company reserves the right to make improvements or changes in the product described in this document at any time and without notice. Furthermore, Dynamic Engineering assumes no liability arising out of the application or use of the device described herein.

The electronic equipment described herein generates, uses, and can radiate radio frequency energy. Operation of this equipment in a residential area is likely to cause radio interference, in which case the user, at his own expense, will be required to take whatever measures may be required to correct the interference.

Dynamic Engineering's products are not authorized for use as critical components in life support devices or systems without the express written approval of the president of Dynamic Engineering.

Connection of incompatible hardware is likely to cause serious damage.



Table of Contents

PRODUCT DESCRIPTION	6
THEORY OF OPERATION	9
PROGRAMMING	11
ADDRESS MAP	12
Register Definitions	13
PMC_B2B_BASE	13
PMC_B2B_USER_SWITCH	15
PMC_B2B_TX_START_LAT	16
PMC_B2B_STATUS	17
PMC_B2B_WR_DMA_PNTR	20
PMC_B2B_RD_DMA_PNTR	20
PMC_B2B_FIFO	21
PMC_B2B_TX_AMT_LVL	21
PMC_B2B_RX_AFL_LVL	22
PMC_B2B_TX_FIFO_COUNT	22
PMC_B2B_RX_FIFO_COUNT	23
Loop-back	23
PMC PCI PN1 INTERFACE PIN ASSIGNMENT	24
PMC PCI PN2 INTERFACE PIN ASSIGNMENT	25
APPLICATIONS GUIDE	26
Interfacing	26
CONSTRUCTION AND RELIABILITY	26
THERMAL CONSIDERATIONS	27

WARRANTY AND REPAIR	27
Service Policy	27
Out of Warranty Repairs	28
For Service Contact:	28
SPECIFICATIONS	29
ORDER INFORMATION	30

List of Figures

FIGURE 1	PMC-SPACEWIRE BLOCK DIAGRAM	6
FIGURE 2	PMC-SPACEWIRE-BS2BI BLOCK DIAGRAM	7
FIGURE 3	PMC-SPACEWIRE-BS2BI TIMING DIAGRAM	10
FIGURE 4	PMC-SPACEWIRE-BS2BI XILINX ADDRESS MAP	12
FIGURE 5	PMC-SPACEWIRE-BS2BI BASE CONTROL REGISTER	13
FIGURE 6	PMC-SPACEWIRE-BS2BI USER SWITCH PORT	15
FIGURE 7	PMC-SPACEWIRE-BS2BI TX START LATCH	16
FIGURE 8	PMC-SPACEWIRE-BS2BI STATUS PORT	17
FIGURE 9	PMC-SPACEWIRE-BS2BI WRITE DMA POINTER REGISTER	20
FIGURE 10	PMC-SPACEWIRE-BS2BI READ DMA POINTER REGISTER	20
FIGURE 11	PMC-SPACEWIRE-BS2BI RX/TX FIFO PORT	21
FIGURE 12	PMC-SPACEWIRE-BS2BI TX ALMOST EMPTY LEVEL REGISTER	21
FIGURE 13	PMC-SPACEWIRE-BS2BI RX ALMOST FULL LEVEL REGISTER	22
FIGURE 14	PMC-SPACEWIRE-BS2BI TX FIFO DATA COUNT PORT	22
FIGURE 15	PMC-SPACEWIRE-BS2BI RX FIFO DATA COUNT PORT	23
FIGURE 16	PMC-SPACEWIRE-BS2BI PN1 INTERFACE	24
FIGURE 17	PMC-SPACEWIRE-BS2BI PN2 INTERFACE	25

Product Description

The PMC-SpaceWire-BS2BI is part of the PMC Module family of modular I/O components by Dynamic Engineering. The PMC-SpaceWire is capable of providing multiple serial protocols. The BS2BI protocol implemented provides a single transmit and receive channel each consisting of four LVDS signals. The data-stream is separated into two signals; the low data line transfers bits 0-15 and the high data line transfers bits 16-31. An enable signal and a gated clock complete the serial protocol.

Other custom interfaces are available. We will redesign the state machines and create a custom interface protocol. That protocol will then be offered as a “standard” special order product. Please see our web page for current protocols offered. Please contact Dynamic Engineering with your custom application.

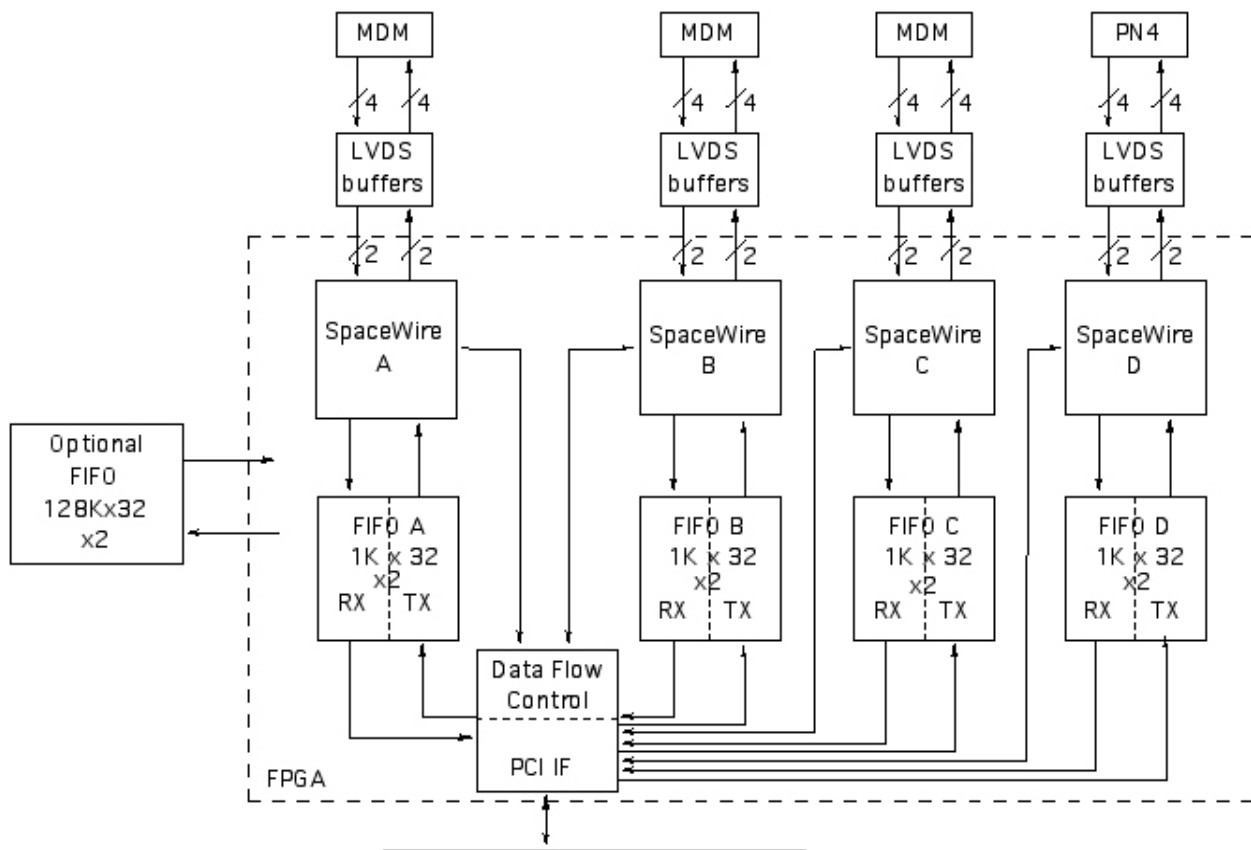

FIGURE 1

PMC-SPACEWIRE BLOCK DIAGRAM

The standard configuration shown in Figure 1 makes use of two external [to the Xilinx] FIFOs. The FIFOs can be as large as 128K deep x 32 bits wide. Most

designs do not require so much memory, and are more efficiently implemented using FIFOs internal to the Xilinx FPGA.

The BS2BI implementation has two 4K by 32-bit FIFOs using the Xilinx internal block RAM, one for the transmitter and one for the receiver. Data is transmitted LSB first in two continuous bit streams as long as the transmitter is enabled and data is present in the TX FIFO.

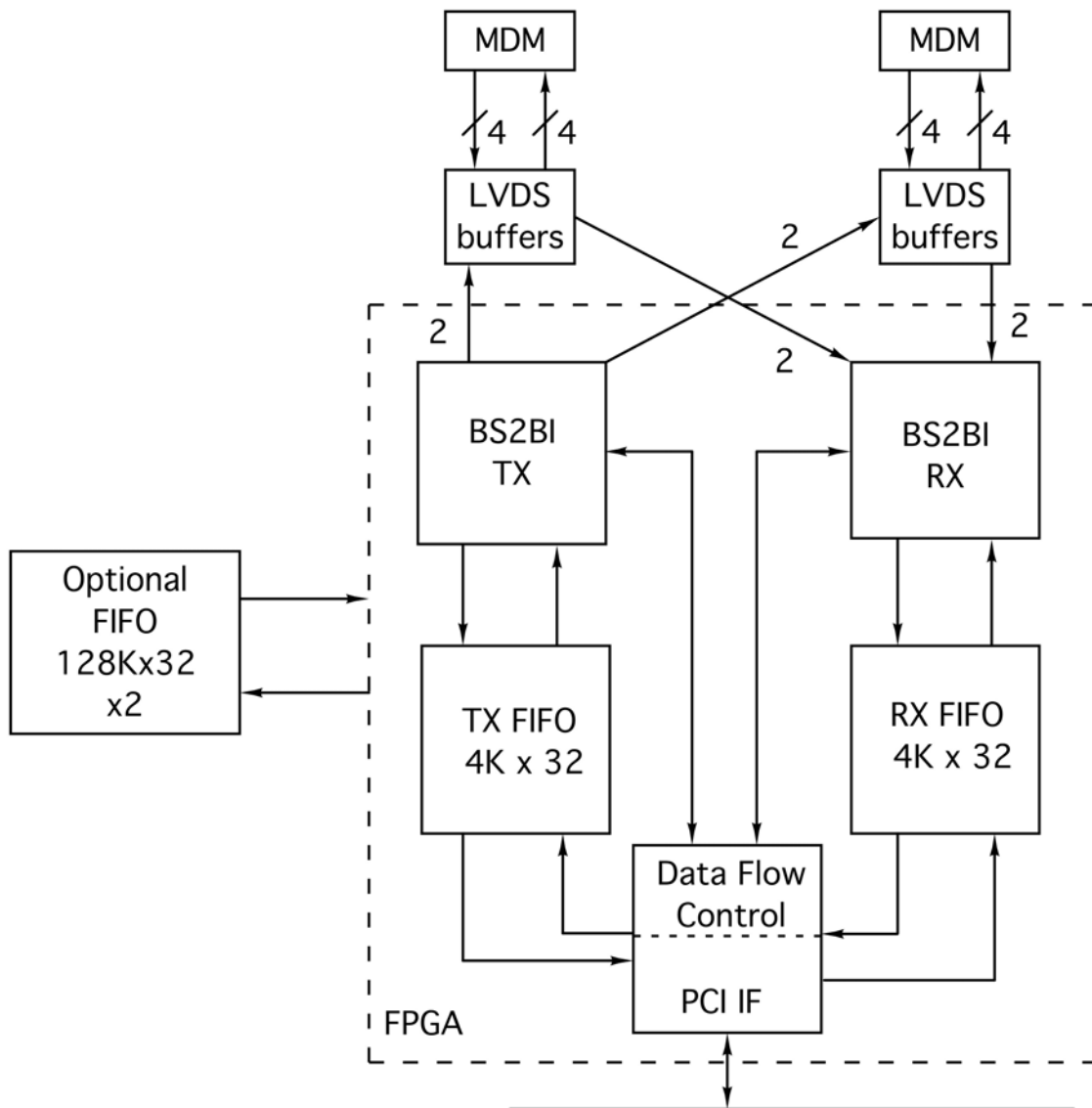

FIGURE 2

PMC-SPACEWIRE-BS2BI BLOCK DIAGRAM

The LVDS signals enter and leave the board through two MDM-9pin connectors. Each connector handles two differential inputs and two differential outputs.

The data rate is derived from a 50 MHz on-board oscillator and can be selected to be 50 Mbps or 10 Mbps.

The PMC-SpaceWire-BS2BI conforms to the PMC and CMC draft standards. This guarantees compatibility with multiple PMC Carrier boards. Because the PMC may be mounted on different form factors, while maintaining plug and software compatibility, system prototyping may be done on one PMC Carrier board, while final system implementation uses a different one.

The PMC-SpaceWire-BS2BI uses a 10 mm inter-board spacing for the front panel, standoffs, and PMC connectors. The 10 mm height is the "standard" height and will work in most systems with most carriers. If your carrier has non-standard connectors (height) to mate with the PMC-SpaceWire-BS2BI, please let us know. We may be able to do a special build with a different height connector to compensate.

Various interrupts are supported by the PMC-SpaceWire-BS2BI. An interrupt can be configured to occur at the end of a transmitted message. An interrupt can be set at the end of a received message or after each received data-word. FIFO level interrupts are also supported. All interrupts are individually maskable, and a master interrupt enable is also provided to disable all interrupts simultaneously. The current status is available making it possible to operate in a polled mode when interrupts are disabled. All configuration registers support read and write operations for maximum software convenience. All addresses are long word (32-bit) aligned.



Theory of Operation

The PMC-SpaceWire-BS2BI features a Xilinx FPGA. The FPGA contains all of the registers, FIFOs and protocol controlling elements of the PMC-SpaceWire-BS2BI design. Only the transceivers, user dip-switch and oscillator are external to the Xilinx device.

The PMC-SpaceWire-BS2BI is a part of the PMC Module family of modular I/O products. It meets the PMC and CMC draft Standards. In standard configuration, the PMC-SpaceWire-BS2BI is a Type 1 mechanical with only low profile passive components on the back of the board, one slot wide, with 10 mm inter-board height. Contact Dynamic Engineering for a copy of this specification. It is assumed that the reader is at least casually familiar with this document and basic logic design.

A logic block within the Xilinx controls the PCI interface to the host CPU. The PMC-SpaceWire-BS2BI design requires one wait state for read or writes cycles to any address. The wait states refer to the number of clocks after the PCI core decode before the “terminate with data” state is reached. Two additional clock periods account for the 1 clock delay to decode the signals from the PCI bus and to convert the terminate-with-data state into the TRDY signal.

Scatter-gather DMA is provided for in this design. Once the physical address of the first chaining descriptor is written to the appropriate DMA pointer register, the interface will read a 12-byte block from this location. The first four bytes comprise a long-word indicating the physical address of the first block of the IO buffer passed to the read or write call. The next four bytes represent a long-word indicating the length of that block. The final four bytes are a long-word indicating the physical address of the next chaining descriptor along with two flag bits, in bit position 0 and 1. Bit zero is set to one if this descriptor is the last in the chain. Bit one is set to one if the IO transfer is from the PMC-SpaceWire-BS2BI board to host memory, and zero if the transfer is from memory to the board. These bits are then replaced with zeros to determine the address of the next descriptor, if there is one.

The PMC-SpaceWire-BS2BI sends data in two streams LSB first with no gaps between words; the low data line transfers bits 0-15 and the high data line transfers bits 16-31. The enable and clock are active only when valid data is being sent. The timing is shown in the figure below.



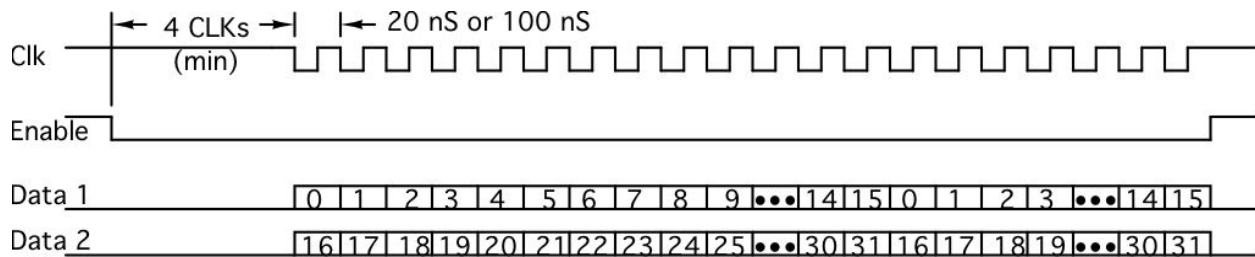

FIGURE 3 PMC-SPACEWIRE-BS2BI TIMING DIAGRAM

The TX data rate is derived from an on-board 50 MHz oscillator that is doubled to 100 MHz in a Xilinx Digital Clock Module. If the 50 MHz clock is selected, the output clock toggles on each clock cycle while data is being transferred. If the 10 MHz clock is selected, the output clock toggles on every fifth clock cycle. The transmitter will continue to send data as long as it is enabled and there is data in the FIFO. When the FIFO becomes empty, a TX interrupt pulse is generated which will clear the TX enable bit unless this function is disabled.

The receiver clocks data into two 16-bit shift registers using the gated clock input. When 32 bits have been received, the data word is assembled and written to the RX FIFO and the process continues. If the interrupt is enabled and the interrupt on each control bit is enabled, an interrupt pulse will be generated as soon as the first word is received; if only the interrupt is enabled, an interrupt pulse will be generated when the enable goes inactive.

TX FIFO almost empty and RX FIFO almost full interrupts can also be used. The levels at which these operate are programmable by writing values into the respective FIFO level registers. The FIFO level interrupts are latched when the TX almost empty or RX almost full FIFO status changes from inactive to active. If the level status changes to inactive again the latch is cleared, otherwise it must be explicitly cleared by writing the same status bit back to the status register address.

Programming

Programming the PMC-SpaceWire-BS2BI requires only the ability to read and write data from the host. The base address is determined during system configuration of the PCI bus. The base address refers to the first user address for the slot in which the PMC is installed.

Depending on the software environment it may be necessary to set-up the system software with the PMC-SpaceWire-BS2BI "registration" data. For example in WindowsNT there is a system registry, which is used to identify the resident hardware.

If DMA is to be used it will be necessary to acquire blocks of non-paged memory that is accessible from the PCI bus in which to store the chaining descriptor list entries.

In order to receive data the software is only required to enable the receiver. To transmit, the software will need to load the message into the TX FIFO, select the clock rate and enable the transmitter.

The interrupt service routine should be loaded and the interrupt mask set. The interrupt service routine can be configured to respond to the FIFO level interrupts or the TX/RX interrupts. After an interrupt is received, new TX data can be written or RX data retrieved. An efficient loop can then be implemented to process the data. New messages can be sent or received even as the current one is in process.

If more than one interrupt is enabled, then the software needs to read the status to see which source caused the interrupt. The status bits are latched, and are explicitly cleared by writing a one to the corresponding bit. It is a good idea to read the status register and write that value back to clear all the latched interrupt status bits before starting a transfer. This will insure that the interrupt status values read by the interrupt service routine came from the current transfer.

Refer to the Theory of Operation section above and the register definition section below for more information regarding the exact sequencing and interrupt definitions.



Address Map

Register Name	Offset	Description
PMC_B2B_BASE	0x0000	Base control register
PMC_B2B_USER_SWITCH	0x0004	User switch read port
PMC_B2B_TX_START_LAT	0x0008	TX start latch
PMC_B2B_STATUS	0x000C	Status register
PMC_B2B_STAT_CLEAR	0x000C	Status latch clear
PMC_B2B_WR_DMA_PNTR	0x0010	Write DMA physical PCI dpr address
PMC_B2B_RD_DMA_PNTR	0x0014	Read DMA physical PCI dpr address
PMC_B2B_FIFO	0x0018	FIFO single word access
PMC_B2B_TX_AMT_LVL	0x001C	TX almost empty level
PMC_B2B_RX_AFL_LVL	0x0020	RX almost full level
PMC_B2B_TX_FIFO_COUNT	0x0024	TX FIFO count
PMC_B2B_RX_FIFO_COUNT	0x0028	RX FIFO count

FIGURE 4

PMC-SPACEWIRE-BS2BI XILINX ADDRESS MAP

The VendorId = 0x10EE. The CardId = 0x0028.

Register Definitions

PMC_B2B_BASE

[0x0000] Base Control Register (read/write)

Base Control Register	
Data Bit	Description
31-16	Spare
15	RX FIFO Almost Full Interrupt Enable
14	TX FIFO Almost Empty Interrupt Enable
13	FIFO Bypass Enable
12	FIFO Reset
11	Spare
10	RX Enable
9	RX Interrupt On Each Enable
8	RX Interrupt Enable
7	50 MHz Clock Select
6	TX Enable (read only)
5	TX Enable Clear Disable
4	TX Interrupt Enable
3	Read DMA Interrupt Enable
2	Write DMA Interrupt Enable
1	Force Interrupt
0	Master Interrupt Enable

FIGURE 5

PMC-SPACEWIRE-BS2BI BASE CONTROL REGISTER

All bits are active high and are reset on power-up or reset command, except PLL enable, which defaults to enabled (high) on power-up or reset.

Master Interrupt Enable: When this bit is set to a one all enabled interrupts (except the DMA interrupts) will be gated through to the PCI host; when this bit is a zero, the interrupts can be used for status without interrupting the host.

Force Interrupt: When this bit is set to a one a system interrupt will occur provided the master interrupt enable is set. This is useful for interrupt testing.

Write/Read DMA Interrupt Enable: These two bits, when set to one, enable the interrupts for DMA writes and reads respectively. The DMA interrupts are not affected by the Master Interrupt Enable.

TX Interrupt Enable: When this bit is set to a one, the transmit interrupt is enabled. A transmit interrupt will be asserted when the transmit FIFO becomes empty during a transmission by setting this bit, provided the master interrupt enable is asserted. When this bit is zero, the transmit interrupt is disabled.

TX Enable Clear Disable: When this bit is zero, the TX start latch will be automatically cleared by the TX interrupt pulse that occurs when the transmitter runs out of data. When this bit is one, the start latch will not be automatically cleared.

TX Enable: This is a read only bit that reflects the state of the TX Start Latch.

50 MHz Clock Select: When this bit is set to a one, the TX state machine will send data at a 50 Mbits/sec rate. When this bit is zero data is sent at a 10 Mbits/sec rate.

RX Interrupt Enable: When this bit is set to a one, the receive interrupt is enabled. A receive interrupt will be asserted, provided the master interrupt is enabled either at the end of a message or when at least one 32-bit word is received depending on the RX Interrupt On Each Enable bit. When this bit is zero, the receive interrupt is disabled.

RX Interrupt On Each Enable: When this bit is set to a one, and the receive interrupt is enabled a receive interrupt will be asserted, provided the master interrupt is enabled when at least one 32-bit word is received. When this bit is zero, and the receive interrupt is enabled, a receive interrupt will be asserted, provided the master interrupt is enabled, when the enable input line becomes inactive.

RX Enable: When this bit is set to a one the receive state-machine is enabled and will start to look for received serial data. When this bit is zero, the receive state-machine is disabled.

FIFO Reset: When this bit is set to a one, the transmit and receive FIFOs will be reset. When this bit is zero, normal FIFO operation is enabled.

FIFO Bypass Enable: When this bit is set to a one, any data written to the transmit FIFO will be immediately transferred to the receive FIFO. This allows for fully testing the data FIFOs without using the IO. When this bit is zero, normal operation is enabled.

TX FIFO Almost Empty Interrupt Enable: When this bit is set to a one, an interrupt will be generated when the transmit FIFO level transitions from not almost empty to almost empty as specified by the level in the PMC_B2B_TX_AMT_LVL register, provided the master interrupt enable is asserted. When this bit is zero, an interrupt will not be generated, but the status can still be read from the status register.

RX FIFO Almost Full Interrupt Enable: When this bit is set to a one, an interrupt will be generated when the receive FIFO level becomes equal or greater to the value specified in the PMC_B2B_RX_AFL_LVL register, provided the master interrupt enable is asserted. When this bit is zero, an interrupt will not be generated, but the status can still be read from the status register.

PMC_B2B_USER_SWITCH

[0x0004] User Switch Port (read only)

Dip-Switch Port	
Data Bit	Description
31-16	Spare
15-8	Xilinx Design Revision Number
7-0	Switch Setting

FIGURE 6 PMC-SPACEWIRE-BS2BI USER SWITCH PORT

Switch Setting: The user switch is read through this port. The bits are read as the lowest byte. Access the read-only port as a long word and mask off the undefined bits. The dip-switch positions are defined in the silkscreen. For example the switch figure below indicates a 0x12.

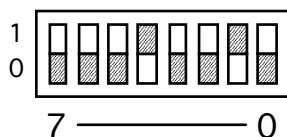

Xilinx Design Revision Number: The value of the second byte of this port is the rev. number of the Xilinx design (currently 0x02 - rev. B).

PMC_B2B_TX_START_LAT

[0x0008] Control Latch (write only)

TX Start Latch	
Data Bit	Description
31-5	Spare
4	TX Enable (write only)
3-0	Spare

FIGURE 7

PMC-SPACEWIRE-BS2BI TX START LATCH

TX Enable: When this bit is set to a one the transmit state-machine is enabled and will start to send serial data as soon as data is available in the TX FIFO. When this bit is zero, the transmit state-machine is disabled. This latch will be automatically cleared when the TX FIFO runs out of data unless the TX Enable Clear Disable bit in the Base Control register is set.

PMC_B2B_STATUS

[0x000C] Status Read / Latch Clear Write Port

Status Register	
Data Bit	Description
31	Local Interrupt Active
30-18	Spare
17	RX FIFO Almost Full Occurred
16	TX FIFO Almost Empty Occurred
15	Read DMA Interrupt Occurred
14	Write DMA Interrupt Occurred
13	Read DMA Error Occurred
12	Write DMA Error Occurred
11	Local Interrupt Condition Occurred
10	RX FIFO Overflow Occurred
9	RX Interrupt Occurred
8	TX Interrupt Occurred
7	Receive Data Valid
6	Receive FIFO Full
5	Receive FIFO Almost Full
4	Receive FIFO Empty
3	Spare
2	Transmit FIFO Full
1	Transmit FIFO Almost Empty
0	Transmit FIFO Empty

FIGURE 8

PMC-SPACEWIRE-BS2BI STATUS PORT

Transmit FIFO Empty: When a one is read, the transmit data FIFO contains no data; when a zero is read, there is at least one data word in the FIFO.

Transmit FIFO Almost Empty: When a one is read, the number of data words in the transmit data FIFO is less than or equal to the value written to the PMC_B2B_TX_AMT_LVL register; when a zero is read, the level is more than that value.

Transmit FIFO Full: When a one is read, the transmit data FIFO is full; when a zero is read, there is room for at least one more data word in the FIFO.

Receive FIFO Empty: When a one is read, the receive data FIFO contains no data; when a zero is read, there is at least one data word in the FIFO.

Receive FIFO Almost Full: When a one is read, the number of data words in the receive data FIFO is greater or equal to the value written to the PMC_B2B_RX_AFL_LVL register; when a zero is read, the level is less than that value.

Receive FIFO Full: When a one is read, the receive data FIFO is full; when a zero is read, there is room for at least one more data word in the FIFO.

Receive Data Valid: When a one is read, there is at least one valid receive data word left. This bit can be set even if the receive FIFO is empty, because as soon as the first four words are written into the FIFO, they are read out to be ready for a PCI read DMA or single word access. When this bit is a zero, it indicates that there is no valid receive data.

TX Interrupt Occurred: When a one is read, it indicates that the transmit state-machine sent some amount of data and then the TX FIFO became empty. A zero indicates that this condition has not occurred. This bit is latched and can be cleared by writing back to the Status register with a one in this bit position.

RX Interrupt Occurred: When a one is read, it indicates that the receive state-machine has received at least one 32-bit data-word. This bit will only be asserted if the RX Interrupt Enable is set in the Base Control register. A zero indicates that this condition has not occurred. This bit is latched and can be cleared by writing back to the Status register with a one in this bit position.

RX FIFO Overflow Occurred: When a one is read, it indicates that an attempt has been made to write data to a full receive data FIFO. A zero indicates that no overflow condition has occurred. This bit is latched and can be cleared by writing back to the Status register with a one in this bit position.

Local Interrupt Condition Occurred: When a one is read, it indicates that an enabled local interrupt condition has occurred. These conditions include the TX and RX interrupts as well as the TX Almost Empty and RX Almost Full interrupts. Also the Force Interrupt bit will cause this bit to be asserted. A system interrupt will occur if the Master Interrupt Enable is set. A zero indicates that no enabled local interrupt condition is active.



Write DMA Error Occurred: When a one is read, a write DMA error has been detected. This will occur if there is a target or master abort or if the direction bit in the next pointer of one of the chaining descriptors is a one. A zero indicates that no write DMA error has occurred. This bit is latched and can be cleared by writing back to the Status register with a one in this bit position.

Read DMA Error Occurred: When a one is read, a read DMA error has been detected. This will occur if there is a target or master abort or if the direction bit in the next pointer of one of the chaining descriptors is a zero. A zero indicates that no read DMA error has occurred. This bit is latched and can be cleared by writing back to the Status register with a one in this bit position.

Write DMA Interrupt Occurred: When a one is read, a write DMA interrupt is latched. This indicates that the scatter-gather list for the current write DMA has completed, but the associated interrupt has yet to be completely processed. A zero indicates that no write DMA interrupt is pending.

Read DMA Interrupt Occurred: When a one is read, it indicates that a read DMA interrupt is latched. This indicates that the scatter-gather list for the current read DMA has completed, but the associated interrupt has yet to be completely processed. A zero indicates that no read DMA interrupt is pending.

TX FIFO Almost Empty Occurred: When a one is read, it indicates that the transmit FIFO has become almost empty. A zero indicates that no TX FIFO almost empty has occurred. This bit is latched and can be cleared by writing back to the Status register with a one in this bit position.

RX FIFO Almost Full Occurred: When a one is read, it indicates that the receive FIFO has become almost full. A zero indicates that no RX FIFO almost full has occurred. This bit is latched and can be cleared by writing back to the Status register with a one in this bit position.

Local Interrupt Active: When a one is read, it indicates that a system interrupt is asserted caused by an enabled local interrupt condition. A zero indicates that no system interrupt is pending from an enabled local interrupt condition

PMC_B2B_WR_DMA_PNTR

[0x0010] Write DMA Pointer (write only)

DMA Pointer Address Register	
Data Bit	Description
31-0	First Chaining Descriptor Physical Address

FIGURE 9 PMC-SPACEWIRE-BS2BI WRITE DMA POINTER REGISTER

This write-only port is used to initiate a scatter-gather write DMA. When the address of the first chaining descriptor is written to this port, the DMA engine reads three successive long words beginning at that address. The first is the address of the first memory block of the DMA buffer containing the data to write to the device, the second is the length in bytes of that block, and the third is the address of the next chaining descriptor in the list of buffer memory blocks. This process is continued until the end-of-chain bit in one of the next pointer values read indicates that it is the last chaining descriptor in the list.

PMC_B2B_RD_DMA_PNTR

[0x0014] Read DMA Pointer (write only)

DMA Pointer Address Register	
Data Bit	Description
31-0	First Chaining Descriptor Physical Address

FIGURE 10 PMC-SPACEWIRE-BS2BI READ DMA POINTER REGISTER

This write-only port is used to initiate a scatter-gather read DMA. When the address of the first chaining descriptor is written to this port, the DMA engine reads three successive long words beginning at that address. The first is the address of the first memory block of the DMA buffer where the data from the device will be stored, the second is the length in bytes of that block, and the third is the address of the next chaining descriptor in the list of buffer memory blocks. This process is continued until the end-of-chain bit in one of the next pointer values read indicates that it is the last chaining descriptor in the list.

PMC_B2B_FIFO

[0x0018,] Write TX/Read RX FIFO Port

RX and TX FIFO Port	
Data Bit	Description
31-0	FIFO data word

FIGURE 11

PMC-SPACEWIRE-BS2BI RX/TX FIFO PORT

This port is used to make single-word accesses to the TX and RX FIFOs.

PMC_B2B_TX_AMT_LVL

[0x001C] TX almost-empty level (read/write)

TX Almost-Empty Level Register	
Data Bit	Description
31-16	Spare
15-0	TX FIFO almost-empty level

FIGURE 12 PMC-SPACEWIRE-BS2BI TX ALMOST EMPTY LEVEL REGISTER

This read/write port accesses the transmitter almost-empty level register. When the number of data words in the transmit data FIFO is equal or less than this value, the almost-empty status bit is set.

An interrupt may be generated if it is enabled when the FIFO level transitions from not almost-empty to almost-empty.

PMC_B2B_RX_AFL_LVL

[0x0020] RX almost-full level (read/write)

RX Almost-Full Level Register	
Data Bit	Description
31-16	Spare
15-0	RX FIFO almost-full level

FIGURE 13 PMC-SPACEWIRE-BS2BI RX ALMOST FULL LEVEL REGISTER

This read/write port accesses the receiver almost-full level register. When the number of data words in the receive data FIFO is equal or greater than this value, the almost-full status bit is set.

An interrupt may be generated if it is enabled when the FIFO level transitions from not almost-full to almost-full.

PMC_B2B_TX_FIFO_COUNT

[0x0024] TX FIFO data count (read only)

TX FIFO Data Count Port	
Data Bit	Description
31-12	Spare
11-0	TX data words stored

FIGURE 14 PMC-SPACEWIRE-BS2BI TX FIFO DATA COUNT PORT

This read-only register port reports the number of 32-bit data words in the transmit FIFO (currently a maximum of 0xFFF).

PMC_B2B_RX_FIFO_COUNT

[0x0028] RX FIFO data count (read only)

RX FIFO Data Count Port	
Data Bit	Description
31-12	Spare
11-0	RX data words stored

FIGURE 15 PMC-SPACEWIRE-BS2BI RX FIFO DATA COUNT PORT

This read-only register port reports the number of 32-bit data words in the receive FIFO (currently a maximum of 0xFFF).

Loop-back

The Engineering kit has reference software, which includes external loop-back tests. The PMC-SpaceWire-BS2BI has two 9-pin MDM front panel connectors. The tests require two loop-back plugs with the following pins connected.

Signal	From	To	Signal
TX DATA LO+	J2 pin 8	J2 pin 2	RX DATA LO+
TX DATA LO-	J2 pin 4	J2 pin 7	RX DATA LO-
TX DATA HI+	J2 pin 9	J2 pin 1	RX DATA HI+
TX DATA HI-	J2 pin 5	J2 pin 6	RX DATA HI-
TX CLOCK+	J4 pin 9	J4 pin 1	RX CLOCK+
TX CLOCK-	J4 pin 5	J4 pin 6	RX CLOCK-
ENABLE OUT+	J4 pin 8	J4 pin 2	ENABLE IN+
ENABLE OUT-	J4 pin 4	J4 pin 7	ENABLE IN-

PMC PCI Pn1 Interface Pin Assignment

The figure below gives the pin assignments for the PMC Module PCI Pn1 Interface on the PMC-SpaceWire-BS2BI. See the User Manual for your carrier board for more information. Unused pins may be assigned by the specification and not needed by this design.

TCK	-12V	1	2
GND	INTA#	3	4
		5	6
BUSMODE1#	+5V	7	8
		9	10
GND		11	12
CLK	GND	13	14
GND		15	16
	+5V	17	18
	AD31	19	20
AD28	AD27	21	22
AD25	GND	23	24
GND	C/BE3#	25	26
AD22	AD21	27	28
AD19	+5V	29	30
	AD17	31	32
FRAME#	GND	33	34
GND	IRDY#	35	36
DEVSEL#	+5V	37	38
GND	LOCK#	39	40
		41	42
PAR	GND	43	44
	AD15	45	46
AD12	AD11	47	48
AD9	+5V	49	50
GND	C/BE0#	51	52
AD6	AD5	53	54
AD4	GND	55	56
	AD3	57	58
AD2	AD1	59	60
	+5V	61	62
GND		63	64

FIGURE 16

PMC-SPACEWIRE-BS2BI PN1 INTERFACE

PMC PCI Pn2 Interface Pin Assignment

The figure below gives the pin assignments for the PMC Module PCI Pn2 Interface on the PMC-SpaceWire-BS2BI. See the User Manual for your carrier board for more information. Unused pins may be assigned by the specification and not needed by this design.

+12V		1	2
TMS	TDO	3	4
TDI	GND	5	6
GND		7	8
		9	10
		11	12
RST#	BUSMODE3#	13	14
	BUSMODE4#	15	16
	GND	17	18
AD30	AD29	19	20
GND	AD26	21	22
AD24		23	24
IDSEL	AD23	25	26
	AD20	27	28
AD18		29	30
AD16	C/BE2#	31	32
GND		33	34
TRDY#		35	36
GND	STOP#	37	38
PERR#	GND	39	40
	SERR#	41	42
C/BE1#	GND	43	44
AD14	AD13	45	46
GND	AD10	47	48
AD8		49	50
AD7		51	52
		53	54
	GND	55	56
		57	58
GND		59	60
		61	62
GND		63	64

FIGURE 17

PMC-SPACEWIRE-BS2BI PN2 INTERFACE

Applications Guide

Interfacing

Some general interfacing guidelines are presented below. Do not hesitate to contact the factory if you need more assistance.

ESD

Proper ESD handling procedures must be followed when handling the PMC-SpaceWire-BS2BI. The card is shipped in an anti-static, shielded bag. The card should remain in the bag until ready for use. When installing the card the installer must be properly grounded and the hardware should be on an anti-static workstation.

Start-up

Make sure that the "system" can see your hardware before trying to access it. Many BIOS will display the PCI devices found at boot up on a "splash screen" with the VendorID and CardID and an interrupt level. Look quickly, if the information is not available from the BIOS then a third party PCI device cataloging tool will be helpful. We use PCView.

Watch the system grounds

All electrically connected equipment should have a fail-safe common ground that is large enough to handle all current loads without affecting noise immunity. Power supplies and power consuming loads should all have their own ground wires back to a common point.

We provide the components. You provide the system. Only careful planning and practice can achieve safety and reliability. Inputs can be damaged by static discharge, or by applying voltage outside of the device rated voltages.

Construction and Reliability

PMC Modules were conceived and engineered for rugged industrial environments. The PMC-SpaceWire-BS2BI is constructed out of 0.062-inch thick FR4 material.

Through-hole and surface-mount components are used. The PMC connectors are rated at 1 Amp per pin, 100 insertion cycles minimum. These connectors make consistent, correct insertion easy and reliable.



The PMC is secured against the carrier with four screws attached to the 2 stand-offs and 2 locations on the front panel. The four screws provide significant protection against shock, vibration, and incomplete insertion.

The PMC Module provides a low temperature coefficient of 2.17 W/°C for uniform heat. This is based upon the temperature coefficient of the base FR4 material of 0.31 W/m·°C, and taking into account the thickness and area of the PMC. The coefficient means that if 2.17 Watts are applied uniformly on the component side, then the temperature difference between the component side and solder side is one degree Celsius.

Thermal Considerations

The PMC-SpaceWire-BS2BI design consists of CMOS circuits. The power dissipation due to internal circuitry is very low. It is possible to create higher power dissipation with the externally connected logic. If more than one Watt is required to be dissipated due to external loading, then forced-air cooling is recommended. With the one degree differential temperature to the solder side of the board, external cooling is easily accomplished.

Warranty and Repair

Please refer to the warranty page on our website for the current warranty offered and options.

<http://www.dyneng.com/warranty.html>

Service Policy

Before returning a product for repair, verify as well as possible that the suspected unit is at fault. Then call the Customer Service Department for a RETURN MATERIAL AUTHORIZATION (RMA) number. Carefully package the unit, in the original shipping carton if this is available, and ship prepaid and insured with the RMA number clearly written on the outside of the package. Include a return address and the telephone number of a technical contact. For out-of-warranty repairs, a purchase order for repair charges must accompany the return. Dynamic Engineering will not be responsible for damages due to improper packaging of returned items. For service on Dynamic Engineering Products not purchased directly from Dynamic Engineering contact your reseller. Products returned to Dynamic Engineering for repair by other than the original customer will be treated as out-of-warranty.



Out of Warranty Repairs

Out of warranty repairs will be billed on a material and labor basis. The current minimum repair charge is \$100. Customer approval will be obtained before repairing any item if the repair charges will exceed one half of the quantity one list price for that unit. Return transportation and insurance will be billed as part of the repair and is in addition to the minimum charge.

For Service Contact:

Customer Service Department
Dynamic Engineering
435 Park Dr.
Ben Lomond, CA 95005
831-336-8891
831-336-3840 fax
support@dyneng.com



Specifications

Host Interface:	PMC (PCI Mezzanine Card)
Serial Interfaces:	One input and one output BS2BI interface
TX Bit-rates generated:	10 or 50 Mbits/sec
Software Interface:	Control Registers, FIFOs, and Status Ports
Initialization:	Hardware reset forces all registers to 0 except as noted
Access Modes:	LW boundary Space (see memory map)
Wait States:	One for all addresses
Interrupt:	TX FIFO almost empty, RX FIFO almost full, TX done, RX data received, read, and write DMA done.
DMA:	Scatter/Gather DMA Support implemented
Onboard Options:	All Options are Software Programmable
Interface Options:	Two 9-pin MDM connectors.
Dimensions:	Standard Single PMC Module
Construction:	FR4 Multi-Layer Printed Circuit, Through-Hole and Surface-Mount Components
Temperature Coefficient:	2.17 W/°C for uniform heat across PMC
Power:	Max. TBD mA @ 5V



Order Information

PMC-SpaceWire-BS2BI

http://www.dyneng.com/pmc_SpaceWire.html

Standard version with two 4KB FIFOs per channel, standard SpaceWire [ECSS-E-50-12A] timing and protocol. Three channels through the Bezel and 1 on Pn4

PMC-SpaceWire-BS2BI-Eng-1

Engineering Kit for the PMC-SpaceWire-BS2BI board-level schematics (PDF) and 9-pin MDM loop-back plugs (2).

PMC-SpaceWire-BS2BI-Eng-2

Board-level schematics [PDF], Software Driver and sample application, and 9-pin MDM loop-back plugs (2).

MDMCable9

9-pin MDM connectors (2) - four shielded twisted pairs

All information provided is Copyright Dynamic Engineering

